

MESSRS.

SPECIFICATION FOR APPROVAL

承 認 書

Product	MAGNETIC BUZZER INDICATOR
Part No.	AX-1205-LF
Customer Approval	

Approved By	Checked By	Made By
工程 部 許俊程 2004-NOV-11	工程 部 許俊程 2004-NOV-11	工程 部 許俊程 2004-NOV-11



ADVANCED ACOUSTIC TECHNOLOGY CORP.

苙 翔 科 技 股 份 有 限 公 司

2F, No.207, Sec. 6, Chung Shan N. Rd., Taipei, Taiwan, R.O.C.

Tel: +886-2-88665255

Fax: +886-2-88665250

E-mail: <http://www.aatc.com.tw>



ISO 9001 Certified

1. Specifications

AX-1205-LF

Items		Units	Specifications	Conditions
01	Pb,Cd content	ppm	Pb < 100 , Cd < 5	
02	Rated Voltage	VDC	5	Response Time 500 mSec
03	Operating Voltage	VDC	4~7	Volts D.C
04	Consumption Current	mA (Max)	Mean 35	Applying rated voltage
			Peak 105	
05	Direct Current Resistance	Ohm	None	
06	Sound Output	dBA (min)	85	Distance at 10cm,applying rated voltage
07	Basic Frequency	Hz	2300± 300	
08	Operating Temp.	°C	-20 ~ +70	
09	Storage Temp.	°C	-30 ~ +80	
10	Weight	Gram	2	

2. Measuring Method

2-1. Test Condition

STANDARD

Temperature : 15 ~ 35°C

Relative humidity : 25% ~ 85%,

Atmospheric pressure : 860mbar to 1060mbar.

JUDGEMENT

Temperature : 20±3°C

Relative humidity : 60% ~ 70%,

Atmospheric pressure : 860mbar to 1060mbar

2-3. Standard Test Fixture

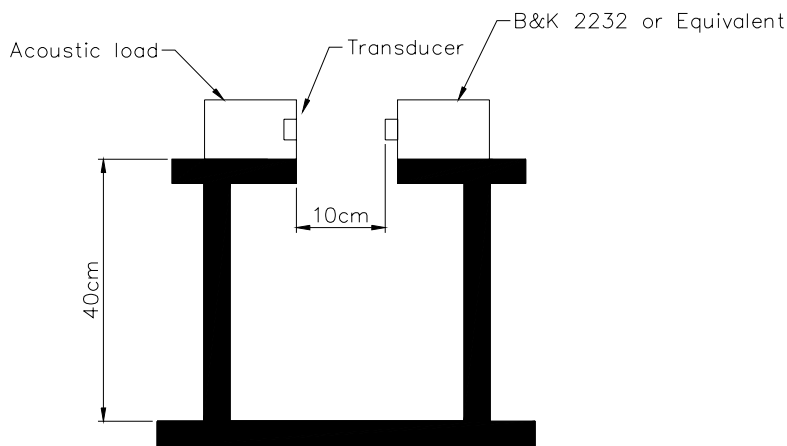

2-4. Frequency Response Curve

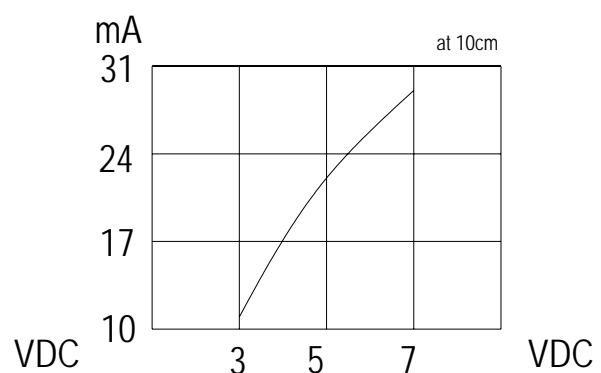
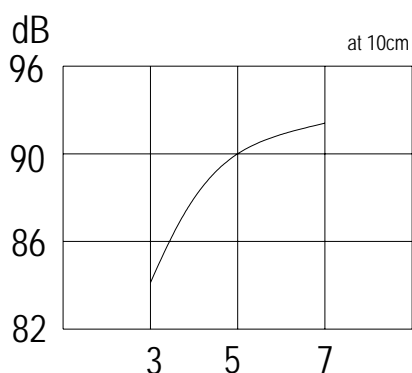

REV NO.

REVISION NOTE

APPROVAL

DATE

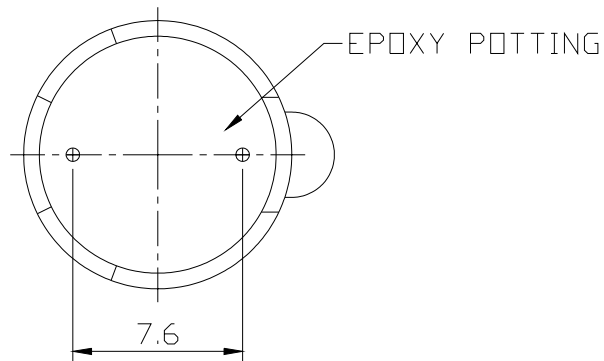
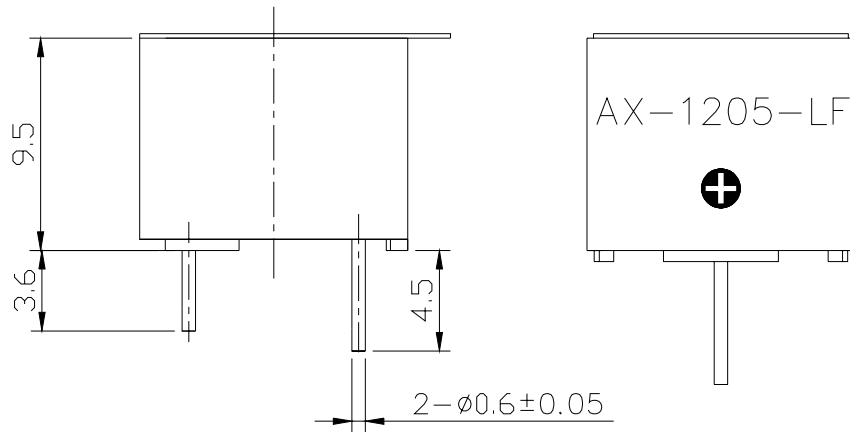
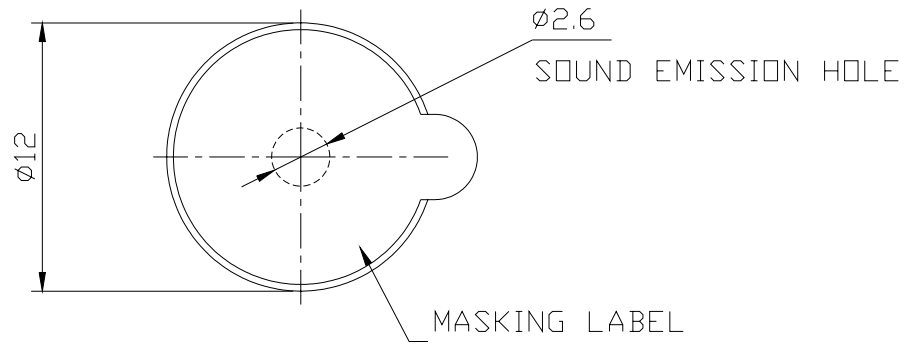

TITLE: SOUND TRANSDUCER DIMENSIONS		DRAWN: JOHN	2003/11/26	SCALE: 3/1	SHEET: 1 of 1
PART NO. AX-1205-LF		DESIGNED: R&D OF AAT		UNITS: mm	
DWG NO. DTT-1045		CHECKED:		TOLERANCE ± 0.5	
REV 1		APPROVAL:		UNLESS OTHERWISE SPECIFIED:	
		MATERIAL: NORYL		ONE PLACE DECIMAL \pm ***	
				TWO PLACE DECIMAL \pm ***	
				THREE PLACE DECIMAL \pm ***	



ADVANCED ACOUSTIC TECHNOLOGY CORPOATION

4.RELIABILITY TEST

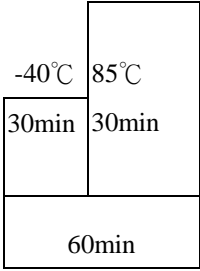
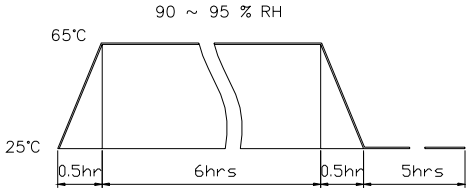
Item	Test conditions	Evaluation standard
01 High temp.Storage life	The part shall be capable of withstanding a storage Temperature of 95°C for 96 hours.	<p>After the test the part shall meet specifications without Any degradation in appearance and performance except S.P.L S.P.L shall be 78dB or more.</p>
02 Low temp.Storage life	The part shall be capable of withstanding a storage Temperature of -50°C for 96 hours.	
03 Temp. cycle	<p>The part shall be subjected 10 cycles. One cycle shall consist of;</p> 	
04 Temp./Humidity cycle	<p>The part shall be subjected 10 cycles. One cycle shall be 12 hours and consist of;</p> 	
05 Operating life	<p>Rated Voltage applied.</p> <ol style="list-style-type: none"> Ordinary temperature The part shall be subjected to 1000 hours at room temperature (25 ±10°C) High temperature The part shall be subjected to 500 hours at 85°C Low temperature The part shall be subjected to 500 hours at -40°C 	
06 Lead Strength	Pull load on the direction of the lead axis for 10 ±1 sec.	
07 Vibration	The part shall be subjected to a vibration cycle of 10Hz to 55Hz to 10Hz in a period of 1 minute. Total peak amplitude shall be 1.52mm (9.3G). The vibration test shall consist of 2 hours per plane in each three mutually perpendicular planes for a total time of 6 hours.	

Item		Test conditions	Evaluation standard
08	Fixed drop	The part shall be mounted on standard pc board and dropped from a height of 152cm onto a concrete floor 5 times in each 6 planes.(a total of 30 times)	<p>After the test the part shall meet specifications without Any degradation in appearance and performance except S.P.L</p> <p>S.P.L shall be 78dB or more.</p>
09	Free drop	The part only shall be dropped from a height of 75cm onto a 40mm thick wooden board 3 times in 3 axes (X.Y.Z). (a total of 9 times).	
10	Solder heat resistance	Soldering into solderbath : $350\pm 5^{\circ}\text{C}$ Soaking time : 3.5 ± 0.5 sec	
11	Solder ability	Soldering : $250\pm 5^{\circ}\text{C}$ / 5 Sec. $350\pm 5^{\circ}\text{C}$ / 1.5 Sec Soldering t into solderbath : $250\pm 5^{\circ}\text{C}$ Soaking time : 2 ± 0.5 sec.	
12	Lead strength	Pull lead with a force of 10N,on the direction of the lead axis for 10 : 10 ± 1 sec	
13	Washability	Solvent : deionized water Solvent temp. : $55\pm 5^{\circ}\text{C}$ Soaking time : 5 ± 0.5 min.	